

**WARNING: For correct operation & installation, it is essential to observe these instructions.**

## COMPACT REVERSE OSMOSIS



*Note: The whole house water filtration system works as the pre-filtration stages that a regular reverse osmosis needs.*

**Important Notice:** Please remember to document your service schedule on page 24 of this booklet for easy reference and maintenance tracking. Your diligent record-keeping ensures timely and efficient maintenance, guaranteeing the longevity and optimal performance of your filtration system.

Product Code: **SYS-ROCOMP**

## CONTENTS

Compact Reverse Osmosis .....	1
Installation and Operation Manual .....	3
AquaCo Customer Service .....	3
Minimum and Maximum Operating Conditions .....	3
Operation .....	3
Installation .....	4
Typical Installation .....	5
Installation Images .....	6
Before installation .....	7
Installation Procedure .....	7
Faucet Installation Procedure .....	10
Faucet Dimensions .....	12
Guide to use Push-In Tube Connectors .....	14
Use Guidelines .....	14
Cartridge Replacement Guide .....	15
Inline Carbon filter & Alkalisising filter Service / Maintenance .....	17
Membrane Service/Maintenance .....	19
Notes .....	21
Warranty .....	21
Acceptance and Claims .....	21
Risk .....	22
Retention of Title .....	22
Rights Forfeited .....	22
Price .....	23
Default .....	23
Severence .....	23
Jurisdiction .....	23
Warranty/Australia .....	23
Service Schedule .....	24

Product Code: SYS-ROCOMP

## INSTALLATION AND OPERATION MANUAL

### AQUACO CUSTOMER SERVICE

Thank you for purchasing the AquaCo Compact Reverse Osmosis System. Your system is a proven performer manufactured from only quality materials and components and will give years of 'spring fresh' water free of impurities if maintained properly.

Caution: Do not use with water that is microbiologically unsafe or with water of unknown quality without adequate disinfection before or after the system.

The system is designed for town or city water supplies but can be used in other situations. For other types of water supply please contact your local AquaCo stockist or call our AquaCo Customer Service Helpline.

The AquaCo filter systems cartridges need replacing regularly to maintain optimum performance. This is a simple procedure when following instructions. For cartridge replacements contact your nearest AquaCo stockist.

Customer Service Helpline 1300 70 1300 (Australia).

### MINIMUM AND MAXIMUM OPERATING CONDITIONS

Condition	Minimum	Maximum
Inlet Pressure	240 kPa	600* kPa
Inlet Temperature	0°C (Protect from freezing)	30°C
Inlet TDS	50 mg/L	2,000 mg/L
Inlet Hardness	0 mg/L (0 grain)	171 mg/L (10 grain)
Inlet Silt Density Index	0	5 NTU

**Note:** Where line pressure exceeds 500 kPa, an approved pressure limiting device must be installed to comply with Australian & New Zealand Plumbing Standards.

### OPERATION

The AquaCo reverse osmosis systems is designed to run economically for many years, dependent on the initial installation and periodical maintenance.

Flush the system for 10 minutes after any period of non-use longer than 2 days. For a period of non-use of 2 weeks or more, it may be necessary to replace cartridges.

This product must be installed in accordance with local plumbing regulations by a licensed plumber.

**Installation Note:** A water filter system/tap, like any product, has a limited life and may eventually fail. Also, sometimes failure happens early due to unforeseen circumstances. To avoid possible property damage, this product should be regularly examined for leakage and/or deterioration and replaced when necessary. A drain pan, plumbed to an appropriate drain or outfitted with a leak detector, should be used in those applications where any leakage could cause property damage, and/or the water supply should be turned off if no one is home/present.

Product Code: SYS-ROCOMP

**INSTALLATION MUST BE COMPLETED BY A LICENCED PLUMBER. FAULTY OPERATION DUE TO UNQUALIFIED PERSONS WILL RESULT IN VOIDED WARRANTY COVERAGE.**

*Note: Chlorine (free chlorine) tolerance is 1ppm - high chlorine levels permanently damage the reverse osmosis membrane and is not covered under warranty. The maintenance of the pre-filtration system is always recommended to protect the performance of the reverse osmosis membrane.*

## INSTALLATION

This system comes complete with an installation kit enabling it to be connected to ½" copper pipe (cold supply only - hot water should be filtered prior to heating). Included is a control valve incorporating backflow prevention, anti-hammer, flow control and pressure limiting capabilities in full compliance with the relevant laws.

### INSTALLATION REQUIREMENTS

1. **Water Line:** ½" BSP cold water line.
  - **Note:** Alternative fittings may be required if being connected to anything other than 15mm (½") copper pipe.
2. **Min/Max pressure:** 240 - 600 kPa.
  - **Note:** If your water pressure is under 35 psi (240 kPa), you may be required to fit a booster pump for optimum performance of the system.
3. **Min/Max temperature:** 0° - 30°C (protect from freezing).
4. **Location for Faucet:** Ensure there is a suitable location to install the dedicated drinking faucet.

### SYSTEM DIMENSIONS

- **System Dimensions:** 300 W x 200 H x 100 D (mm)
- **Reverse Osmosis Tank Dimensions:**
  - **12 L Capacity Reverse Osmosis Tank (RO-122)**
    - **Tank Dimensions:** 244 mm (Diameter) × 366 mm (Height)
    - **Total Volume (Full Capacity):** 12 liters
    - **Usable Storage Capacity:** ~7 to 8.5 liters (depends on water pressure and tank position)
  - **18 L Capacity Reverse Osmosis Tank (RO-132)**
    - **Tank Dimensions:** 279 mm (Diameter) × 368 mm (Height)
    - **Total Volume (Full Capacity):** 18 liters
    - **Usable Storage Capacity:** ~12 liters (depends on water pressure and tank position)
- **Dedicated Drinking Faucet Dimensions:** 292 H x 80 W x 130 D (mm)
  - **Note:** Instead of having a separate faucet for filtered water, consider having a 3 Way Mixer to avoid drilling a hole through your stone/wood benchtop.

### TOOLS & MATERIALS REQUIRED

- |                              |                                 |                                                 |
|------------------------------|---------------------------------|-------------------------------------------------|
| • Plumbing knowledge         | • Drill                         | • Masking tape                                  |
| • Towel (for water spillage) | • 7mm & 12.5 drill bits         | • Container or bucket (to catch residual water) |
| • Measuring tape             | • 2 x adjustable tools/crescent |                                                 |
| • Sharp utility knife        | • Safety glasses                |                                                 |
| • Philips screwdriver        | • Pencil                        |                                                 |

Product Code: SYS-ROCOMP

TYPICAL INSTALLATION

Figure 1

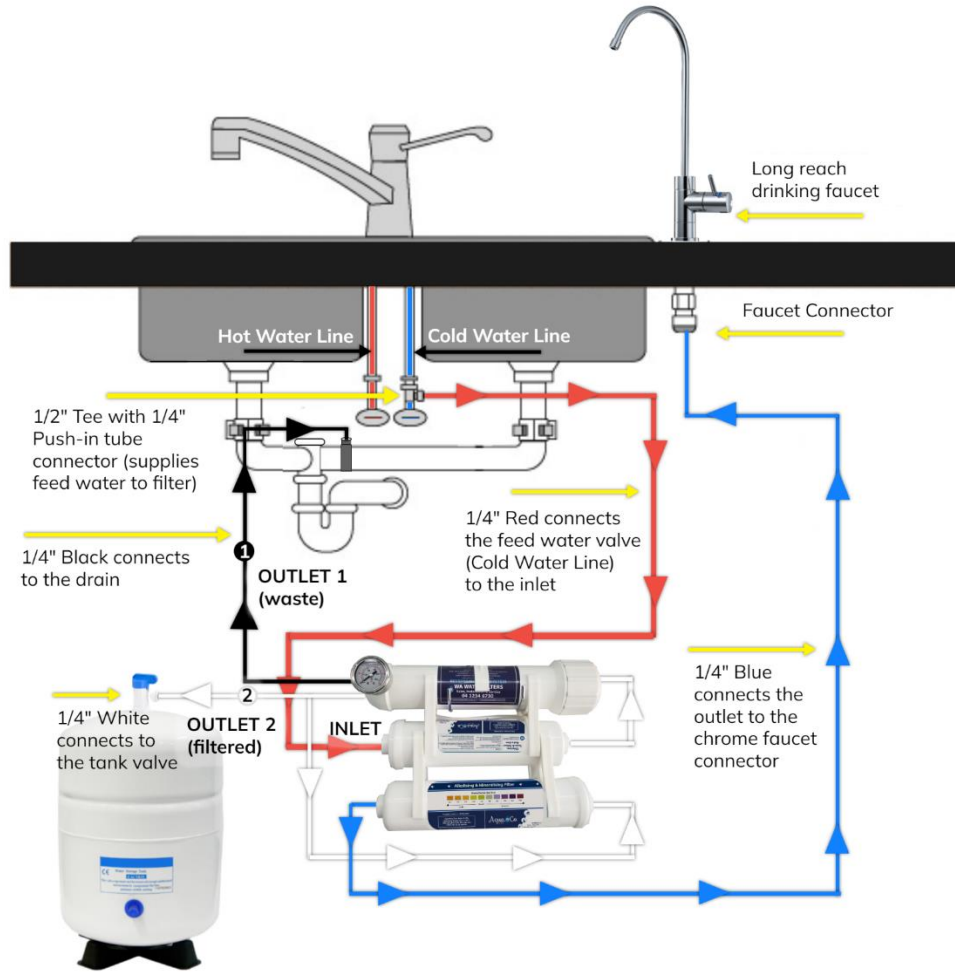

**Note:** Tubing is colour coded for ease of installation.

**RED** - WATER FEED: 1/4" Red Tube Connects to the Mains Connector.

**BLACK** – WATER WASTE: 1/4" Black Tube Connects Drain Clamp.

**WHITE** – FEEDS TANK: 1/4" White Tube Connects to Tank Shut-Off Valve.

**BLUE** – PURE ALKALINE WATER: 1/4" Blue Tube

MAIN COMPONENTS

- 1/2" Tee with 1/4" Push-In Tube Connector
- 550 kPa PLV Pressure Limiting Valve
- 3 Stage Filtration System
  - a. 1<sup>st</sup> Stage Inline Filter (Inline GAC Pre-Filter)
  - b. 2<sup>nd</sup> Stage Housing with Reverse osmosis Membrane
  - c. 3<sup>rd</sup> Stage Inline Filter (Alkalising/Mineralising Filter)
- 1/4" Flow Restrictor
- 1/4" Quick Connect Drain Clamp
- 1/4" Check Valve
- 1/4" Quick Connect Tee
- 1/4" Auto Shut-Off Valve
- 1/4" Tank Tap Ball Valve
- 8 L Capacity Reverse Osmosis Tank (RO-122)
- Chrome Dedicated Drinking Tap with LED Indicator

Product Code: SYS-ROCOMP



1. ¼" **Red Tube** Connects to the Mains Connector
2. ¼" **Blue Tube** Connects to Faucet
3. ¼" **Black Tube** Connects Drain Clamp
4. ¼" **White Tube** Connects to Tank Shut-Off Valve

#### INSTALLATION IMAGES



Product Code: **SYS-ROCOMP**

---

## BEFORE INSTALLATION

Your water filter has been pre-assembled and air pressure tested for leaks before packing. However, due to transportation, some fittings may have loosened or become unseated. It's important to check the following before installation.

- Tubing and fittings
- Tubing connections (between tube and fittings)
- O-rings
- Housings and filters
  - Tighten and secure any loose parts as necessary.

---

## INSTALLATION PROCEDURE

### 1. Find a convenient location:

The System dimensions are:

- **System:** 300 W x 200 H x 100 D (mm)
- **Tank:**
  - **12 L Capacity Reverse Osmosis Tank (RO-122)**
    - **Tank Dimensions:** 244 mm (Diameter) x 366 mm (Height)
  - **18 L Capacity Reverse Osmosis Tank (RO-132)**
    - **Tank Dimensions:** 279 mm (Diameter) x 368 mm (Height)

Note: If necessary, the tank can be placed on its side, and the system can be laid flat if height is a concern. However, we recommend installing the system upright with at least 50mm clearance underneath to make cartridge changes easier.

### 2. Shut Off the water supply:

Locate the connection between the kitchen tap & cold-water line (Usually a flex line). Shut off the incoming water and open the kitchen cold water tap to release the pressure.

### 3. Disconnect the cold water braided hose:

Note: **If you do not know which one is the hot or cold, run the hot water for a while and feel the hoses.**

### 4. Install the Mains Connector or Isolation Valve:

From the **cold-water inlet**, install the valve adaptor/mains connector in between. **DO NOT** apply thread tape to these connections as they are designed to use the washers only.

Figure 3



Product Code: SYS-ROCOMP

Figure 4

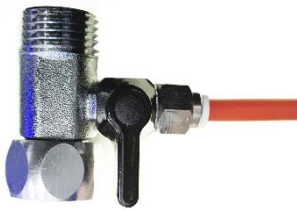

**5. Connect ¼" RED tube to Mains Connector or Isolation Valve:**

Push the red tubing straight into the fitting until it reaches the tube stop. Then, secure with the red clip.

**6. Check for leaks:**

With the black handle facing in line with the cold-water line (Fig 4) the valve is in the off position. During this point, you can re-connect the cold water braided hose and turn your water supply back on to check for leaks in the valve installation.

**7. Choose faucet location:**

Select your preferred location at the kitchen sink to install the faucet. Make sure there is enough access under the benchtop to connect the water hose and fittings. Ensure you reach the underside of the faucet stem to attach the hose and fittings.

The faucet supplied with the system requires a ½" hole (12.5 mm) hole. Use a centre punch to locate the position to drill.

**8. To install faucet, insert the faucet into the hole in sink or bench:**

The faucet may be installed on any flat surface over 50mm (2") in diameter. (Remember: check the underside of the location for interference). Make a small indent using a centre punch to mark the desired drilling location. Drill a pilot hole with a metal drill, then enlarge the hole using a 1/2" metal drill bit.

Be sure to check underside of the benchtop to avoid any interference when drilling.

**8. Once the hole has been drilled install the faucet as per Figure 7 on Page 10.**

Be sure the faucet body, chrome plate, and the black rubber washer are placed above the sink. Install the black locating washer, the lock washer and nut underneath, then tighten firmly while aligning faucet in the desired direction. **Push the BLUE tube to the end of the faucet stem.**

**10. Reset LED indicator by following instructions on page 11.**

**11. Install the drain clamp by drilling a 4 mm hole in the waste pipe:**

Position the drain clamp above the trap. **Connect ¼" BLACK drain tube to drain clamp** and tighten compression nut. Do not allow drain hose to protrude more than 10 mm into drain, making sure the holes in the drain and the clamp are exactly aligned. This can be done by inserting a thin Phillips screwdriver through them whilst tightening the clamp.



Figure 5

Important Note: Do not cut the BLACK tube when installing this system.

**Note: When connecting the red, black, blue and white tubes leave plenty of extra length so that the purifier can be repositioned during servicing without having to disconnect all the hoses.**

Product Code: SYS-ROCOMP

12. Screw ball valve to tank outlet and ensure valve is open. **Connect WHITE tube to storage tank.** (Fig 6)
13. Once unit has been completely plumbed in, it will need to be actuated.
  - a. **To do this ensure isolation valve is off and faucet is open.**
  - b. **Gradually open isolation valve to begin water production.** The first sign will be water running to drain. This is normal and then finally product water will begin coming out faucet. This may take several minutes.
  - c. **At this stage close faucet. This forces product water to fill up the storage tank. To check that water is still being produced, check water is running to drain. This should continue for several hours until tank is full.**
  - d. When tank is full, the pressure in the tank will overcome the inlet water pressure and the shut off valve will activate, shutting off the inlet water.
  - e. To check this, check if water is running to drain. **Once tank is full, no water should run to drain.**
  - f. To flush system, open dedicated drinking tap until water stops, close faucet and allow tank to fill.
  - g. Check all connections for leaks.



Figure 6

14. Reverse osmosis systems produce purified water gradually — typically drop by drop. If the storage tank starts empty, it will take approximately **3 to 4 hours to fill**, depending on your incoming water pressure.

**Before consuming the water**, it is essential to **fill and fully empty the tank at least twice**. This process flushes out any sterilising agents or residues from the membrane used during manufacturing.

**Remember to flush the system by opening the dedicated drinking tap until the water stops. Then close the faucet and allow the tank to refill.**

Ensure that **all plumbing connections are properly tightened** and inspect the system for any leaks.

During initial installation, once the unit and water lines are in place, allow the system to **run for at least 4 hours** before using the purified water for drinking.

Product Code: SYS-ROCOMP

FAUCET INSTALLATION PROCEDURE

Figure 7 – Faucet Installation Diagram

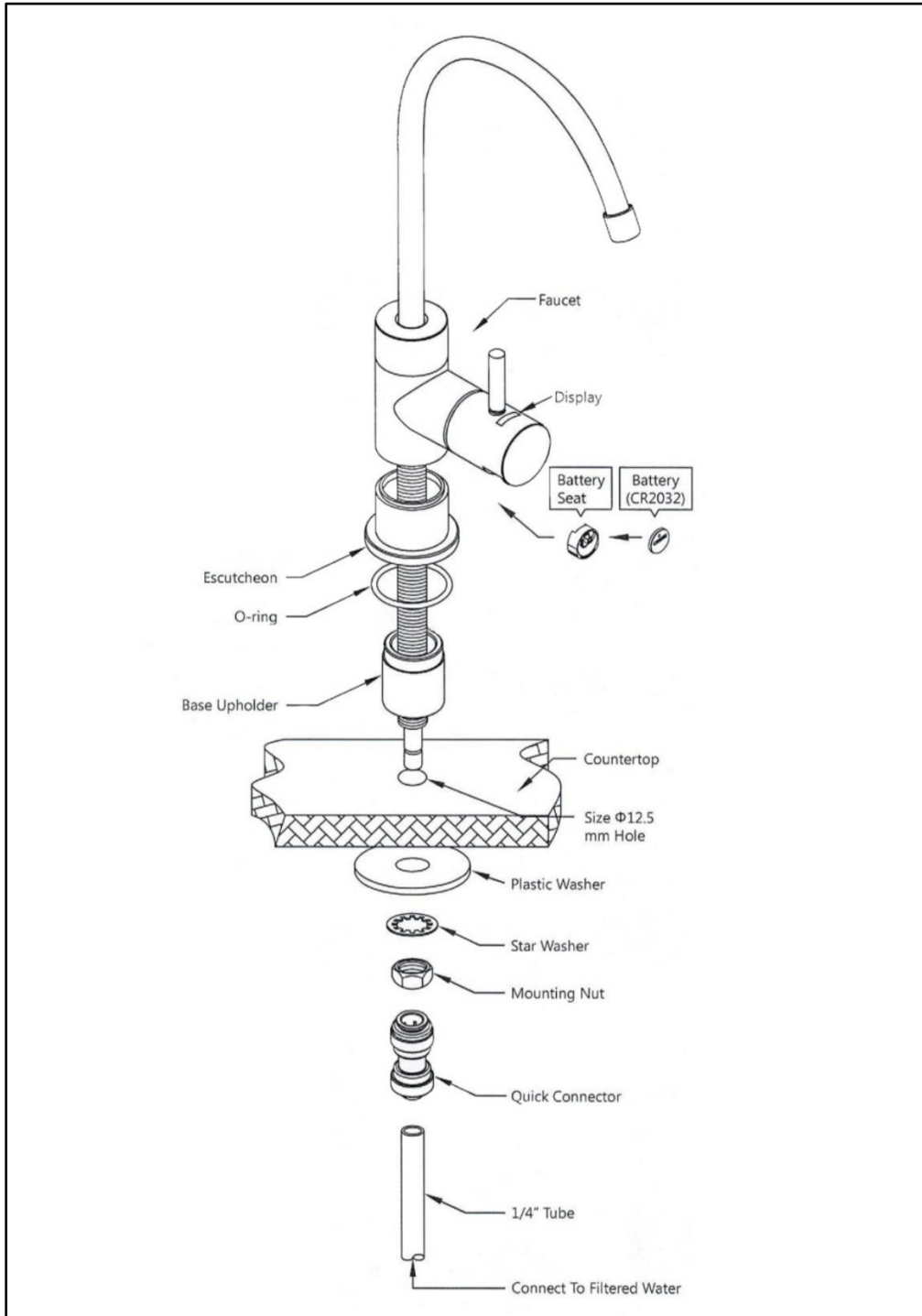

**WARNING! THIS PRODUCT CONTAINS A BATTERY. ACCIDENTAL INGESTION MAY OCCUR AND CAN BE FATAL. PLEASE KEEP OUT OF REACH FROM INFANTS. IF YOU SUSPECT AN ACCIDENTAL INGESTION, PLEASE CONTACT EMERGENCY SERVICES.**

Product Code: SYS-ROCOMP

**BATTERY INSTALLATION**

1. **Remove** the black battery seat from the faucet lever handle.

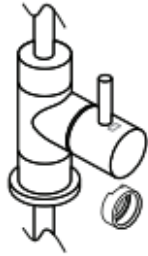

2. **Install battery** into the battery seat, positive side up, discard plastic insert.

Note: Keep your hands dry before installing or replacing the battery of the led to prevent the led circuit board from water or moisture damage.

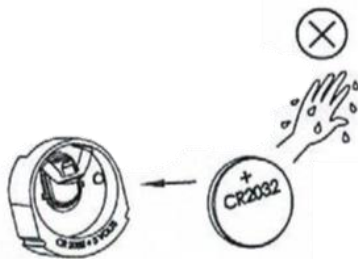

3. **Reset:** When installing or replacing battery, it will flash three times.



4. **Reinstall battery seat assembly** into the faucet lever, battery side facing outwards. The slotted end must be oriented toward the faucet.

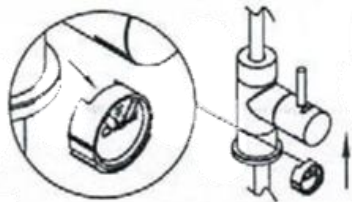

5. **Open filtered water** with blue signal 5 times only.



**BATTERY REPLACEMENT & RESET**

1. **AFTER ONE YEAR** - When the light flashes RED indicates your cartridges are due to be changed (usage has exceeded 3,000 minutes or 12 months).

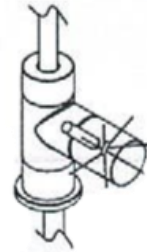

2. **Remove** the black battery seat from the faucet lever handle.

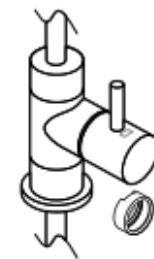

3. After one year When changing cartridges, please **replace the battery**.

Note: Keep your hands dry before installing or replacing the battery of the led to prevent the led circuit board from water or moisture damage.

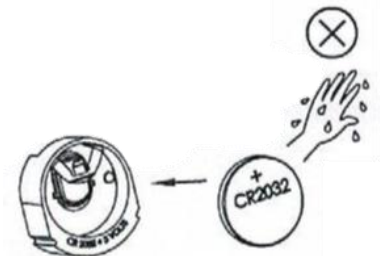

4. After replacing the battery, press the **RESET button** and hold for 5 seconds until it flashes RED-BLUE-RED.

RESET Button

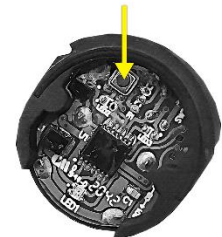

5. **Reinstall battery seat assembly** into the faucet lever, battery side facing outwards. The slotted end must be oriented toward the faucet.

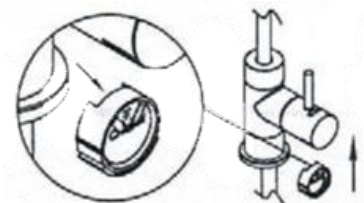



Product Code: SYS-ROCOMP

---

### LED LIGHT INDICATOR

1. After the battery is installed, **the light will flash Blue during operation**. The light will flash red after 1 year.
2. When the light flashes RED indicates your cartridges are due to be changed (usage has exceeded 3,000 minutes or 12 months). After changing the battery or replacing the cartridges, please RESET the battery.
3. At the beginning will be flashing BLUE. After 355 days will be flashing YELLOW. Then, after 365 days, will be flashing RED.
4. To RESET the battery or to program 365 days (1 year): Press for 5 seconds until flashing Red – Blue – Red.

**Important note:** Battery must be replaced and RESET when changing cartridges.

### SCAN QR CODE

A video on **how to reset your LED battery** can be accessed quickly via the QR code, using a device with a QR reader application.

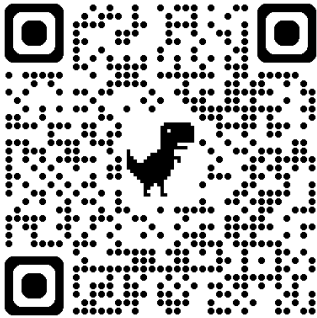

---

### FAUCET MAINTENANCE AND CARE

Occasional cleaning of aerator is recommended.

1. Use of soapy water and a soft sponge or cloth is recommended.
2. Avoid cleaning with chemicals, solvents or harsh elements. (THIS MAY SERIOUSLY HARM SURFACE AREA)
3. If used with hard water or water with high mineral content, it is absolutely necessary to clean and dry the faucet immediately after every use. (CALCIUM AND OTHER MINERALS COULD SERIOUSLY DAMAGE SURFACE AREA)
4. Please wipe the canopy and keep your hands dry before installing or replacing the battery of the LED to prevent circuit board from water or moisture damage.
5. When installing with filtration system with carbon filters or changing carbon filters, it's suggested to flush the filtered tubes from the system before connecting with the faucet to prevent possible carbon dust contamination into faucet cartridge to cause leaking.

GUIDE TO USE PUSH-IN TUBE CONNECTORS

Figure 9

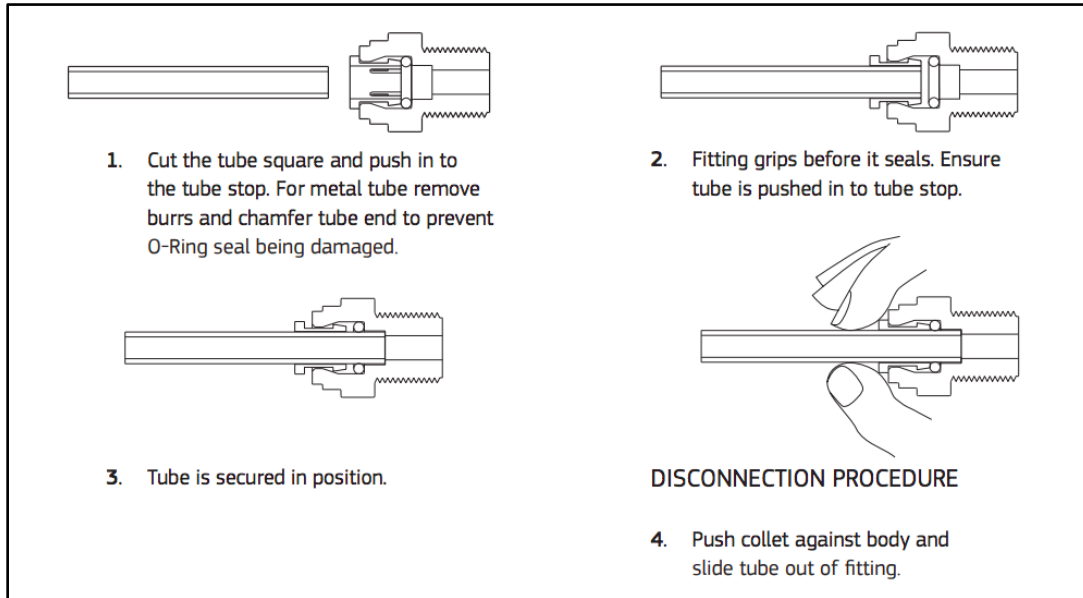

USE GUIDELINES

- Minimum operating pressure 240 kPa (35 psi)
- Maximum operating pressure 600 kPa (85 psi)
- Do not allow exposure to temperatures below 0°C.
- Maximum operating temperature 38°C.
- Nominal flow rate 4 lpm.
- This system must be installed according to local plumbing codes on the cold-water line.
- Replacement Cartridges: See Cartridge replacement section (See Page 15).
- This system requires regular replacement of the filter cartridge to maintain proper operation. Varying chlorine, sediment, or organic substance levels may affect replacement frequency.
- Be sure to change the filter cartridge at least every 12 months; or whenever you detect a change in taste, odour, or decrease in flow.
- **When replacing cartridge, ensure you reset the LED reminder light by removing/replacing the battery from the rubber seat. Please refer to page 11 for a detailed diagram.**

SCAN QR CODE

A **service video** can be accessed quickly via the QR code, using a device with a QR reader application.

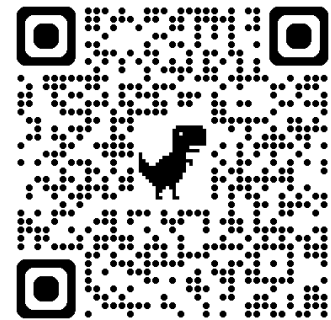

**Caution:** Do not use with water that is microbiologically unsafe or of unknown quality without adequate disinfection before or after the system.

Product Code: SYS-ROCOMP

### CARTRIDGE REPLACEMENT GUIDE

You can obtain replacements from your local AquaCo dealer. To maintain performance, warranty and standards use genuine AquaCo replacements.

Figure 10



**1**

**In-line GAC Filter**

Protects the RO Membrane. Removes chlorine, taste & odours, cloudiness and colors.

**6-12 months**



**2**

**RO Membrane**

Produces bottled quality drinking water by removing up to 99% of over 1,000 harmful contaminants.

**3-4 years**



**3**

**Alkalising Filter**

Adds Calcium, Magnesium and Potassium. Raises the pH level of the water.

**12-24 months**



REMOVES UP TO  
**99.9%**  
IMPURITIES



Reverse Osmosis (RO) converts your water into clean, pure and healthy drinking water by removing up to 99% of over 1,000 harmful contaminants like chlorine, fluoride, lead (removes up to 98%), arsenic, asbestos, calcium, sodium and more.

- 1<sup>st</sup> Stage: Carbon In-line Filter: IL-1125T40JJ-5
- 2<sup>nd</sup> Stage: 75 GPD Membrane: MEM-75GPD
- 3<sup>rd</sup> Stage: Alkalising Filter: IL-1125JJ-ALK

TO MAINTAIN THE HIGH QUALITY OF THE PURIFIED WATER THE CARTRIDGE(S) NEED CHANGING EVERY 6-18 MONTHS (THIS IS DEPENDENT ON WATER QUALITY AND USAGE). YOU CAN OBTAIN REPLACEMENT CARTRIDGES FROM YOUR LOCAL AQUACO STOCKIST. TO MAINTAIN PERFORMANCE AND WARRANTY USE GENUINE AQUACO REPLACEMENTS.

Product Code: SYS-ROCOMP

PRODUCT CODE: IL-1125T40JJ-5

## CARBON FILTER

<b>Micron Rating</b>	<b>&gt;98% @ 5 µm (Nominal)</b>
<b>Filter Dimensions</b>	11" x 2.5"
<b>Chlorine Reduction &gt;95%</b>	6,819 L @ 0.75 gpm
<b>Initial _P</b>	>5.0 psid @0.75 gpm
<b>Carbon Type</b>	Powdered Activated Carbon Block

NOTES: CHLORINE REDUCTION CAPACITY BASED ON LABORATORY TESTING CONDUCTED USING TEST PROTOCOL CONTAINED IN NSF STANDARD 42 AND 53.

PRODUCT CODE: MEM-75GPD

## REVERSE OSMOSIS MEMBRANE

Reverse Osmosis Element	Applied Pressure		Permeate Flow Rate		Typical Stabilized Salt Rejection (%)
	(psig)	(bar)	(GPD)	(L/h)	
<b>TW30-1812-75</b>	50	3.4	50	7.9	99%

1. PERMEATE FLOW AND SALT REJECTION BASED ON THE FOLLOWING TEST CONDITIONS: 500 PPM NAHCO<sub>3</sub> , 77°F (25°C), PH 8.0, 15% RECOVERY AND THE SPECIFIED APPLIED PRESSURE.
2. MINIMUM SALT REJECTION IS 98.0%.
3. PERMEATE FLOWS FOR INDIVIDUAL ELEMENTS MAY VARY +25/-15%.

PRODUCT CODE: IL-1125JJ-ALK

## INLINE ALKALISING FILTER

<b>Micron Rating</b>	<b>&gt;98% @ 5 µm (Nominal)</b>
<b>Filter Dimensions</b>	11" x 2.5"
<b>Initial _P</b>	>5.0 psid @0.75 gpm
<b>Media Type</b>	Magnesium Shavings, Mineral Stones, Coconut Shell Granular Activated Carbon, Poly Sediment Pad, and 5um Sediment Filter Pad.

## MAINTENANCE FOR PERIODS OF TIME WITHOUT OPERATION

The unit cannot be stored for more than 2 weeks without use, or damage to the membrane may occur. Please enquire if this is the case. For a period of non-use greater than 2 days, flush for 10 minutes before use. For non-use periods of more than 2 weeks, the cartridges may need replacing.

The carbon filter should be replaced every 12 months and the alkalising filter every 24 months. The membrane should be replaced when water quality deteriorates or every 36 - 48 months, depending on incoming water quality. Use only genuine AquaCo replacement cartridges and cartridges that are suitable for this appliance. Follow cartridge replacement guide in Page 15.

Product Code: SYS-ROCOMP

INLINE CARBON FILTER & ALKALISING FILTER SERVICE / MAINTENANCE

**1. CLOSE ISOLATING VALVE** - Locate your isolating valve connected to your cold-water supply. Turn isolating valve OFF to prevent water flow.



**2. CLOSE TANK TAP** - Locate the tap on top of your tank and close the valve on top of your tank.



**3. OPEN DRINKING TAP** - Go to your drinking faucet and open the tap to release the pressure.



**4. DISENGAGE TUBINGS** – Locate the filter cartridge to be replaced, and disconnect the hoses connected to that filter. To disconnect the hose/tube, first remove the red clip. **Use two fingers to push into the collet and at the same time pull out the tube.** Repeat the same process to disconnect the hose at the other end of the filter.

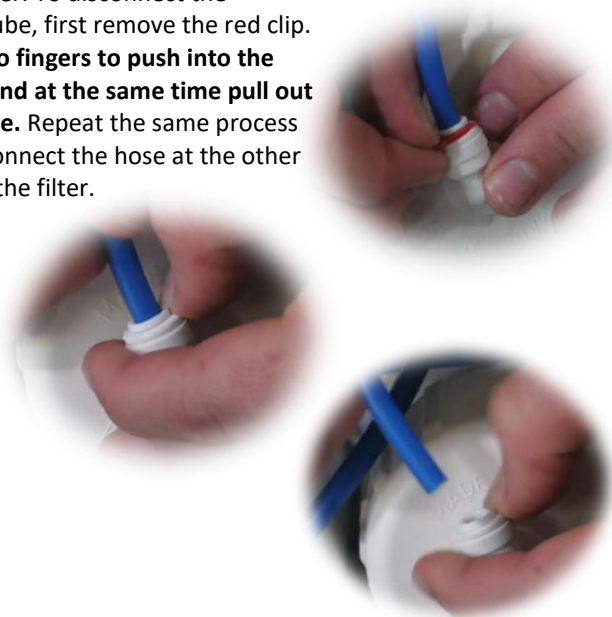

**5. CHECK SPECS** - Before unclipping the filter to remove it, please check the flow arrow and specifications in the current filter to place the new filter in the correct position.

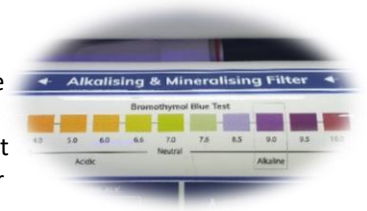

**6. REMOVE PLUGS IN THE NEW FILTER** - To connect the new filter cartridge, remove any protection (plugs) that the filter may have at the ends. Use the step #4 to disengage the plugs in the new filter



**7. CHECK FLOW ARROW** - Check the flow arrow in the new filter and place the new filter in the position as the previous filter was.

Note: When installing the new filter, please double check that the new filter and the current filter have the same specifications

**8. PUSH IN TUBES** - Once the filter is in the right position, push the tube as far as it can go and secure with a John Guest Clip. Then, connect the other end of the filter.



**9. OPEN ISOLATING VALVE** - Locate your isolating valve connected to your cold-water supply. Turn isolating valve ON to allow water flow.



Product Code: SYS-ROCOMP

**10. KEEP DRINKING TAP OPEN** – If closed, turn on the faucet to flush the new filter. **Then, wait 10 minutes.**



**11. OPEN TANK TAP** - Locate the tap on top of your tank and OPEN the valve on top of your tank.



**12. RESET LED INDICATOR** – Close tap and reset LED indicator by following instructions on page 11.



**13. CHECK FOR LEAKS** – Check for leaks rectifying any before leaving the unit. Ensure that all the connections, fittings, and tubing have been pushed in properly.

**Tip! Feel around each fitting with your fingers to detect any moisture or small drips.**

Since a new filter has been installed, pay special attention to the connection where the tube was pushed in.



**14. IF LEAKS OCCUR** - If you find any drips or moisture, mark the location. This will help you locate the issue if you need to shut off the water and drain the system for repairs.

**15. REMEDIATION** - If you detect a leak, shut off the water supply to the RO system immediately.



**16. CHECK FITTINGS OR CONNECTIONS** - If the tubing pulls out easily, it wasn't properly secured. If you find a connection that's not secure, ensure you push the tubing straight into the fitting until it reaches the tube stop.



If a fitting continues to leak even after ensuring proper connection, it may be damaged and may need replacement. If this occurs, please contact us on 1300 70 1300.

**17. FINAL CHECK** - Once you have addressed any issues, turn the water supply back on and monitor for another 1-2 hours to ensure that there are no further leaks.



Product Code: SYS-ROCOMP

## MEMBRANE SERVICE/MAINTENANCE

**1. CLOSE ISOLATING VALVE** - Locate your isolating valve connected to your cold-water supply. Turn isolating valve OFF to prevent water flow.



**2. CLOSE TANK TAP** - Locate the tap on top of your tank and close the valve on top of your tank.



**3. OPEN DRINKING TAP** - Go to your drinking faucet and open the tap to release the pressure.



**4. DISENGAGE TUBINGS** - Disengage the tubing from the membrane housing cap. **Use two fingers to push into the collet and at the same time pull out the tube.**



Note: A complete guide on how to disengage tubing is on Page 14.

**5. OPEN MEMBRANE HOUSING CAP** - Locate your membrane spanner and open the Membrane Housing. Membrane housing cap can be unscrewed by hand.



**6. REMOVE MEMBRANE** - Remove the cap on the membrane housing and by using a pair of needle nose pliers remove the membrane with a twisting motion and discard the Membrane.



**7. REMOVE PACKAGING** - To connect the new filter membrane, remove membrane packaging, only remove the outer shrink-wrap packaging, **DO NOT** remove any other packaging from the membrane.



**8. CHECK MEMBRANE SPECS** - When installing the new membrane, please double check that the new membrane and the old membrane have the same specifications (part number).

**9. INSERT NEW MEMBRANE** - Check the flow arrow in the new membrane and place the new membrane in the position as the previous membrane was. Once the membrane is in the right position, **INSERT THE NEW MEMBRANE.**



**10. LUBRICATE MAIL SEAL** - To make sure the membrane housing is fully sealed; you may use plumbers' silicone grease to lubricate the O-ring and the main seal.

**Product Code: SYS-ROCOMP**

**11. CLOSE HOUSING CAP** – Screw in the membrane housing cap by hand and locate your membrane spanner to tighten it.



**12. PUSH IN TUBING** – Connect the tubing. Push the tubes as far as they can go. Then secure tubing with a red clip.



**13. OPEN ISOLATING VALVE** - Locate your isolating valve connected to your cold-water supply. Turn isolating valve ON to allow water flow.



**14. KEEP DRINKING TAP OPEN** – If closed, turn on the faucet to flush the membrane. **Then, wait 10 minutes.**



**15. OPEN TANK TAP** - Locate the tap on top of you tank and OPEN the valve on top of your tank.



**16. RESET LED INDICATOR** - Close the drinking tap and reset LED Indicator by following instructions on page 11.



**17. CHECK FOR LEAKS** – Check for leaks rectifying any before leaving the unit. Ensure that all the connections, fittings, and housings have been tightened properly.

Note: Since new filters have been installed, pay special attention to the gap where the head and the housing sump seal.

**18. IF LEAKS OCCUR** - If you find any drips or moisture, mark the location. This will help you locate the issue if you need to shut off the water and drain the system for repairs.

**19. REMEDIATION** - If you detect a leak, shut off the water supply to the RO system immediately.



**20. TIGHTEN HOUSING, FITTINGS OR CONNECTIONS** - If tightening doesn't stop the leak, you may need to replace the faulty component or fitting, or consider using plumber's tape for threaded connections. If this occurs, please contact us on 1300 70 1300.



**21. FINAL CHECK** - Once you have addressed any issues, turn the water supply back on and monitor for another 1-2 hours to ensure that there are no further leaks.



**Product Code: SYS-ROCOMP**

## NOTES

AquaCo water care products are designed, manufactured and supported by Water Filters Pty Ltd the name you can trust for viable and proven water solutions. The complete range of AquaCo products are developed, refined, made to meet and exceed stringent specifications for the worldwide market.

Important: Sales of products are subject to our Terms and Conditions which are available upon request. All specifications, information and photos are a guide only and are subject to change without notice. Please ring to confirm details. Warning: For correct operation of this appliance, it is essential to observe manufacturer's instructions.

## WARRANTY

Any contract of sale, order, or quotation made or accepted by or on behalf of Water Filters Pty Ltd (trading as AquaCo Filters) is subject to these terms and conditions of sale.

- AquaCo Filters warrants AquaCo Filtration Systems to the original purchaser for a period of 5 years for Retail customers, and 2 years for Wholesale and Trade customers from the date of sale established by the date of the original invoice issued by an authorized distributor.
- AquaCo Filters warrants each new Product to be free from defects in the product for a period of 2 year from the date of retail sale established by the date of the original invoice issued by AquaCo Filters.
- AquaCo Filters reserves the right in instalment sales to grant credit for the value of any Product found to be defective under this Warranty.
- AquaCo Filters will not cover any labour charge incurred by the Buyer for the replacement or repair of any Product.
- The Buyer is responsible for freight and local labour charges for Products the subject of this Warranty.
- This Warranty applies only to the original purchaser of the Product.
- AquaCo Filters' obligation under this Warranty is limited to AquaCo Filters' own option, to either repair or replace the Product, once AquaCo Filters has deemed that the Product is defective or AquaCo Filters may, at its own discretion, refund to the Buyer the purchase price paid for the defective goods.
- This Warranty does not cover any Product that is relocated from the site of its original installation.
- All replaced or exchanged parts taken out under this warranty become the property of AquaCo Filters.
- This Warranty is subject to the Product being properly installed, maintained, being used for its intended purpose and operated strictly in accordance with AquaCo Filters' recommendations and installation guide.
- This Warranty does not extend to a Product that has been modified in any way unless with AquaCo Filters' express consent.
- This Warranty does not cover the normal wear and tear of the Product, or damage caused by misuse, abuse or vandalism. The Warranty does not cover any malfunction or failure resulting from neglect, use of unauthorised parts and accessories or use with higher water pressure than indicated on the Product.
- The Warranty does not extend to damage caused by rain, fire, earthquake or other natural causes or acts of nature.
- It is expressly agreed that this shall be the sole and exclusive remedy of the Buyer stated herein, and under no circumstances shall AquaCo Filters be liable for any costs, loss, expense, damages, special damages, incidental damages or consequential damages arising directly or indirectly from the design, manufacture, sale, use or repair of the Product whether based upon warranty, contract, tort or strict liability.
- All Conditions and Warranties implied by law or statute are hereby expressly negated so far as they lawfully can be.

---

## ACCEPTANCE AND CLAIMS

- Acceptance of the Products shall be deemed for all purposes to have taken place at the expiration from the date of each delivery.
- Any damage caused during or as a result of transit will not be the responsibility of AquaCo Filters.

**Product Code: SYS-ROCOMP**

- Any faulty systems must be returned with the Pressure Limiting Valve.
- In the event of a Warranty Claim, the Product must be forwarded at the Buyer's own risk and expense to AquaCo Filters, together with proof of purchase.
- This limited Warranty is void if the Product under Warranty is presented without the said original invoice.
- AquaCo Filters may request that a Statement accompany the Original Invoice, signed by the Buyer, setting out the following terms:
  - The name and address of the Buyer.
  - The date and by whom the Product was purchased.
  - The date and by whom the Product was installed.
  - The location where the Product was installed.
  - The date and time the Product first appeared to malfunction.
  - The nature of the problem with the Product.
  - The date and time of any and all loss event/s.
  - The date and time AquaCo Filters were first notified of the Product malfunction.
- A failure by the Buyer to submit the said Statement within 28 days, after such request is made by AquaCo Filters, will automatically void the Warranty.
- A failure to answer truthfully or to answer in a way that is misleading, entitles AquaCo Filters to void the Warranty and to notify the police in the event of suspected fraudulent conduct.

---

**RISK**

- The risk in the Product will pass to the Buyer immediately upon the Product leaving AquaCo Filters' premises for delivery to the place designated by the Buyer.

---

**RETENTION OF TITLE**

- AquaCo Filters will retain title to (but not risk in) a Product delivered to the Buyer until AquaCo Filters has received payment in full for such Product from the Buyer.
- The Buyer will store the goods in such a way as to enable them to be separately identified and will keep them insured at its own expense with AquaCo Filters' interest noted on any such insurance cover.
- If the Buyer fails to make any payment when due or becomes bankrupt or becomes insolvent, or has a judgement entered against it in any Court or enters into any scheme of arrangement, composition, or assignment or is in receivership or voluntary administration or liquidation, the Buyer grants AquaCo Filters the license to enter any of the Buyer's premises where the Product is stored, and without notice, to re -take possession of and remove, at the Buyer's cost and expense, the Product in respect of which title has not passed to the Buyer.

---

**RIGHTS FORFEITED**

The Buyer forfeits any right or claim against AquaCo Filters warrantee if:

1. The System is operated with a water temperature higher than 48° Celsius.
2. The System is not serviced every 12 months (18 months for whole house water filters). i.e., replacement of filters, PLV check and assessment of general condition of the system. If the drinking water quality is poor, the System should be serviced before 12 months.
3. The System damage results from water hammer, freezing, neglect or is not installed by a licensed plumber in accordance with the AS3500 plumbing code and installation plan.
4. The System is subject to water pressure that exceeds the maximum recommended pressure.
5. The System is not installed with an Australian Standards approved Pressure Limiting and Dual Check Valve.

**Product Code: SYS-ROCOMP**

6. The System has been found to be tampered with or if the goods have not been operated or maintained strictly in accordance with AquaCo Filters' recommendations.
7. The System is not turned off when the residents are away for over 24 hours.

---

**PRICE**

- The price charged shall be AquaCo Filters' price ruling at the date of delivery unless otherwise agree in writing. Any price indications or price lists are subject to alterations to AquaCo Filters' price ruling at the date service or goods are supplied.
- Prices are as per AquaCo Filters' wholesale unless otherwise agreed in writing.
- The Buyer is responsible to effect and meet the costs of any insurance cover that is deemed necessary.
- Clerical errors in computations, typing or otherwise of "catalogue, quotation, acceptance, invoice, delivery docket or other document" shall be subject to correction.
- Any goods returned through no fault of AquaCo Filters will be subject to a 15% restocking fee.

---

**DEFAULT**

On the happening of any one or more of the following events, namely:

- The Buyer fails to make payment to AquaCo Filters on the due date;
- An administrator or liquidator is appointed over any or all of the assets of the Buyer or a scheme of arrangements is proposed to approve with respect to the Buyer;
- In the case of the Buyer being a natural person, the Buyer commits an act of bankruptcy; then AquaCo Filters may at its option exercise all or any of the following rights (notwithstanding any prior failure to exercise such rights):
  - a. demand payment of the whole of the monies owing from the Buyer to AquaCo Filters and the Buyer agrees to pay the same immediately.
  - B. the Buyer shall pay to AquaCo Filters interest on such amount outstanding at the rate of 2% per month and any costs with respect to solicitors, legal advisors, mercantile agents and other agents acting on behalf of AquaCo Filters in respect of any enforcement hereof or recovery or attempted recovery of monies owing by the Buyer to AquaCo Filters.

---

**SEVERENCE**

If any of these terms or conditions become for any reason wholly or partly invalid, that term or condition shall to the extent of the invalidity be severed without prejudice to the to the continuing force and validity of the remaining terms and conditions.

---

**JURISDICTION**

AquaCo Filters and the buyer agree that this agreement and its provisions shall be construed in accordance with the laws of the State of Western Australia and be resolved by a Western Australian Court.

---

**WARRANTY/AUSTRALIA**

This warranty is given by Water Filters Pty Ltd, ABN 68618671677, telephone no. 1300 70 1300 and email at sales@waterfilter.com.au. This warranty is provided in addition to other rights and remedies you have under law: Our goods come with guarantees which cannot be excluded under the Australian Consumer Law. You are entitled to replacement or refund for a major failure and to compensation for other reasonably foreseeable loss or damage. You are also entitled to have the goods repaired or replaced if the goods fail to be of acceptable quality and the failure does not amount to a major failure.





ABOUT US



Welcome to AquaCo, your trusted partner in water filtration solutions. With over 13 years of dedicated service and a combined experience exceeding 30 years in the water filtration industry, we are proud to have been at the forefront of purifying Australia's water supply. Our mission is simple: to ensure that every Australian has access to the purest water possible.

As a nation-wide leader in water filtration, our reach extends across the entire country. From bustling cities to remote communities, we seamlessly supply and install state-of-the-art filters wherever needed, guaranteeing clean and safe drinking water for all.

At AquaCo, quality is our unwavering commitment. That's why we import premium components from around the globe and assemble our filtration systems in two of Australia's iconic cities: Perth and Sydney. This dual-location operation allows us to cater to diverse needs while maintaining the high standards our customers expect.

We understand the importance of safety and reliability, which is why we only collaborate with licensed plumbers and utilize certified and world-wide tested components in every installation. With our cutting-edge technology, you're not just investing in a filtration system; you're investing in years of research, innovation, and absolute excellence.

Thank you for choosing AquaCo for your water filtration needs. Together, let's ensure a healthier, happier future with clean, pure water for all Australians.

Regards,

**AquaCo Filters Team**

For the latest information, updates, and to stay informed about water filtration news and cutting-edge technologies, be sure to follow us on:

